

50.0 A Single-Phase Silicon Bridge Rectifier
Rectifier Reverse Voltage 50 to 1000V

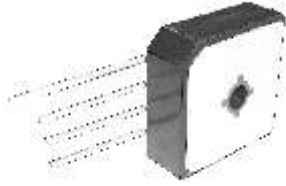

Features

- This series is UL listed under the Recognized Component Index
- Single In-Line terminals array suitable for P.C. board mounting
- Surge overload ratings to 400 amperes
- The plastic material used carries Underwriters Laboratory flammability recognition 94V-0
- Integrally molded heat sinks provide low thermal resistance for maximum heat dissipation
- High temperature soldering guaranteed 265°C /10 seconds at 5 lbs (2.3kg) tension

Mechanical Data

Case: Molded plastic with heat sink integrally mounted in the bridge encapsulation
 Terminals: Plated wire leads solderable per MIL-STD-202, Method 208
 Mounting Position: Any
 Weight: 0.6 ounce, 17 grams (approx)

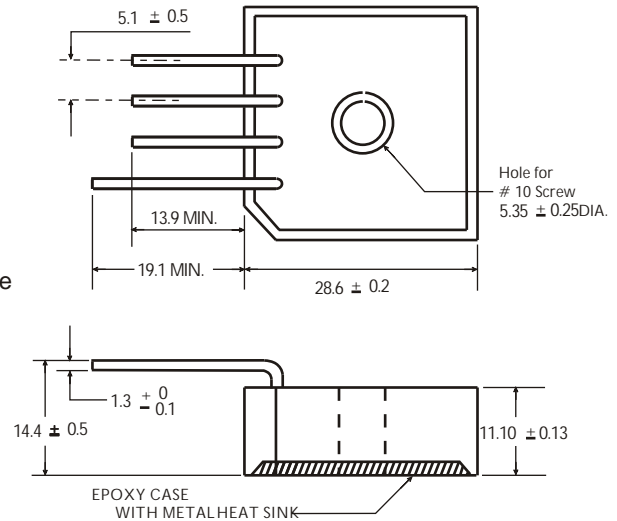

Dimensions in millimeters (1mm=0.0394")

Maximum Ratings & Thermal Characteristics

Rating at 25°C ambient temperature unless otherwise specified, Resistive or Inductive load, 60 Hz.
 For Capacitive load derate current by 20%.

| Parameter | Symbol | MP | MP | MP | MP | MP | MP | MP | Unit |
|---------------------------------------------------------------------------------------|------------------|--------------|-------|-------|-------|-------|-------|-------|--------------------|
| | | 50005S | 5001S | 5002S | 5004S | 5006S | 5008S | 5010S | |
| Maximum repetitive peak reverse voltage | VRRM | 50 | 100 | 200 | 400 | 600 | 800 | 1000 | V |
| Maximum RMS bridge input voltage | VRMS | 35 | 70 | 140 | 280 | 420 | 560 | 700 | v |
| Maximum DC blocking voltage | VDC | 50 | 100 | 200 | 400 | 600 | 800 | 1000 | v |
| Maximum average forward rectified output current at TA=55°C | IF(AV) | 50 | | | | | | | A |
| Peak forward surge current single sine-wave superimposed on rated load (JEDEC Method) | IFSM | 400 | | | | | | | A |
| Rating for fusing (t<8.3ms) | I ² t | 664 | | | | | | | A ² sec |
| Typical thermal resistance per element(1) | ReJA | 2.0 | | | | | | | °C/ W |
| Operating junction and storage temperature range | TJ, TSTG | -55 to + 150 | | | | | | | °C |

Electrical Characteristics

Rating at 25°C ambient temperature unless otherwise specified. Resistive or Inductive load, 60Hz.
 For Capacitive load derate by 20 %.

| Parameter | Symbol | MP | MP | MP | MP | MP | MP | MP | Unit |
|---------------------------------------------------------------------|--------|-----------|-------|-------|-------|-------|-------|-------|------|
| | | 50005S | 5001S | 5002S | 5004S | 5006S | 5008S | 5010S | |
| Maximum instantaneous forward voltage drop per leg at 25.0A | VF | 1.0 | | | | | | | V |
| Maximum DC reverse current at rated DC blocking voltage per element | IR | 10 500 | | | | | | | μA |

Notes: (1)Thermal resistance from Junction to Ambient on P.C.board mounting.

Rating and Characteristic Curves ($T_A=25^{\circ}\text{C}$ Unless otherwise noted)
MP50005S thru MP5010S

Fig. 1 Derating Curve for Output Rectified Current

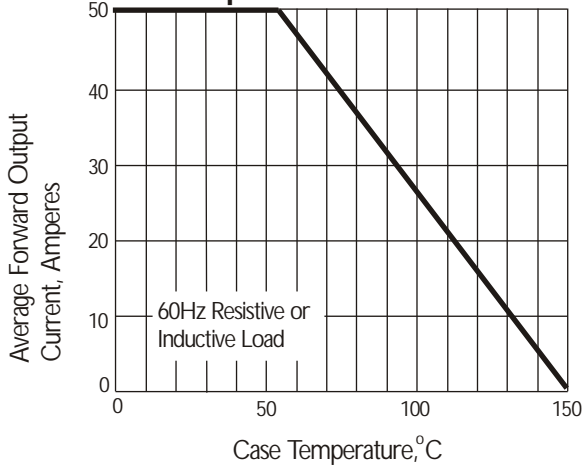

Fig. 2 Maximum Non-repetitive Peak Forward Surge Current

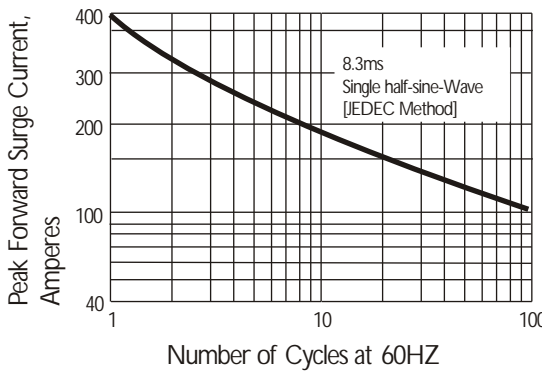

Fig. 3 Typical Instantaneous Forward Characteristics

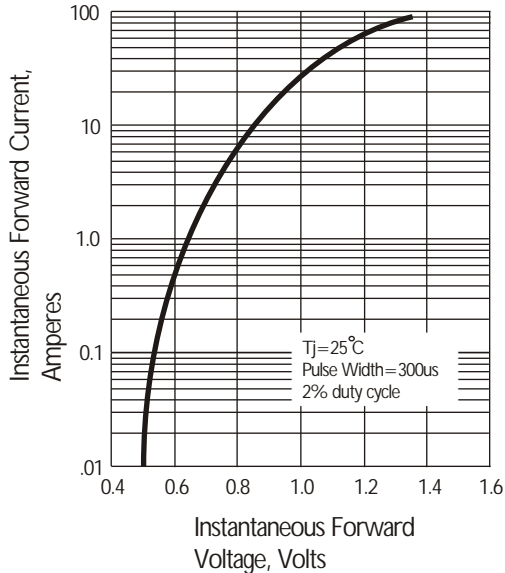

Fig. 4 Typical Reverse Characteristics at $T_J=25^{\circ}\text{C}$

